

# CAN

[ereihani@yahoo.com](mailto:ereihani@yahoo.com)

[s\\_khosro2003@yahoo.com](mailto:s_khosro2003@yahoo.com)

1M Bit/s

CAN

CSMA

) 1M Bit/s

CAN.

(

---

<sup>1</sup> Controller Area Network

CAN

ABS

Robert Bosch

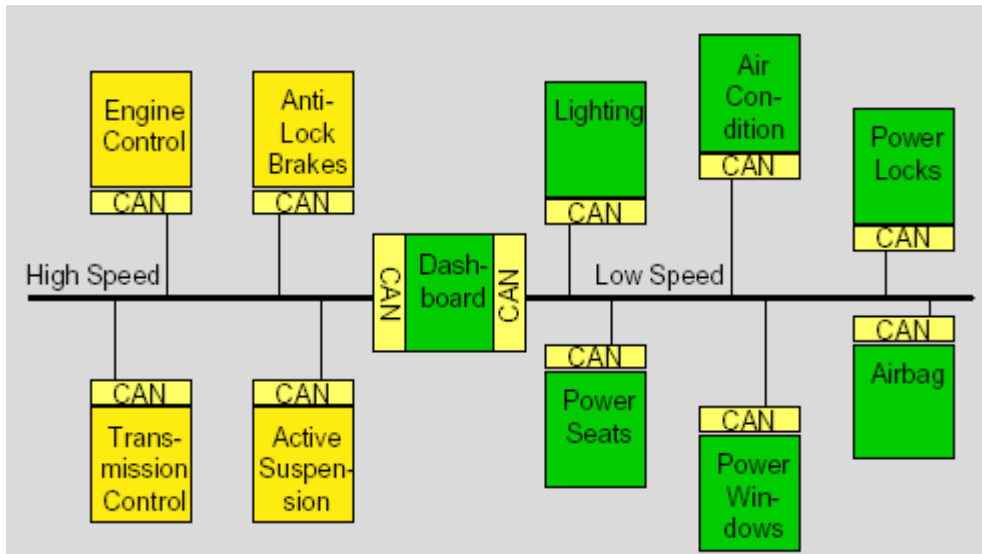

:CAN

CSMA

CSMA/CD (Carrier Sense Multiple Access )

CAN

( )

Collision Detection CD

CAN

A,B,C

B

A,C

C

B

A

A

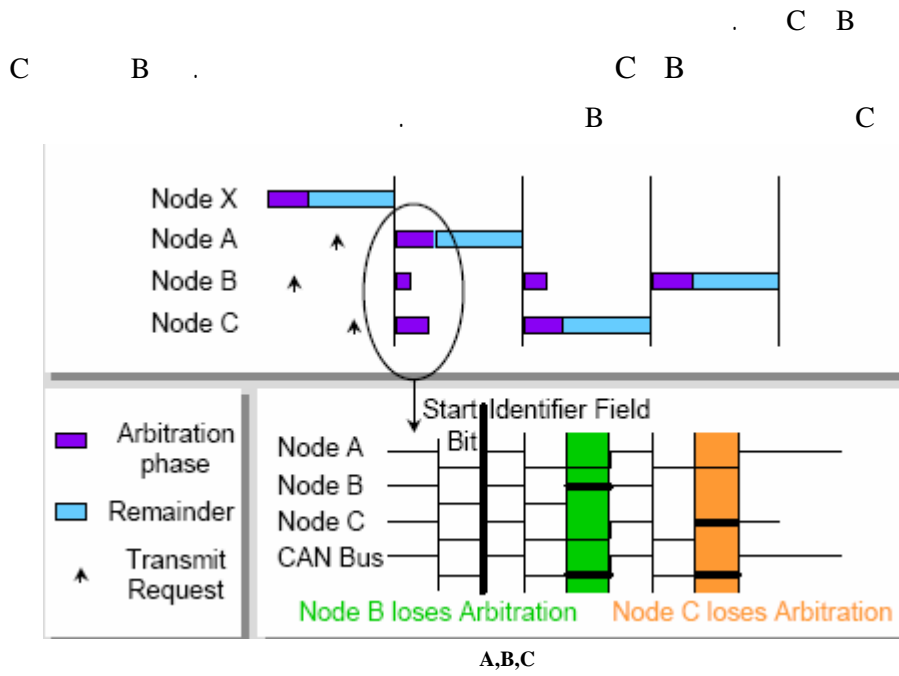

CAN

CAN

CAN

CAN

CAN

( )

CRC

CAN

CAN

CAN  
(RTR)

:CAN

( ) CAN  
 RTR " "  
 IDE ( )  
 ( )  
 CRC  
 ACK  
 "Intermission" " "

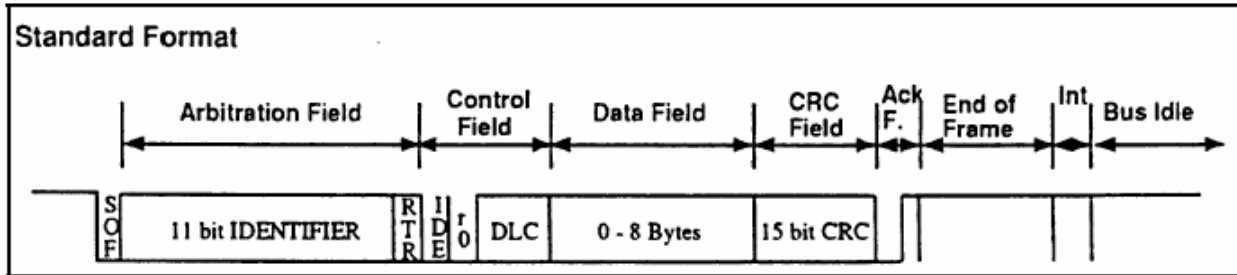

CAN

:CAN

IDE

Extended CAN

Base

:(Cyclic Redundancy Check) CRC

CRC Check

CRC

:Frame Check

Format Error

CAN

CAN

NRZ(Non Return to Zero )

(IVN)

CAN

CAN

CAN

CAN.

CAN

CAN

CAN

CSMA/CD.

CAN

CAN

[1]: [www.can-cia.org](http://www.can-cia.org)

[2]: [www.kvase.com](http://www.kvase.com)

[3]: [www.microchip.com](http://www.microchip.com)

[4]: [www.intel.com](http://www.intel.com)

[5]: [www.dgtech.com](http://www.dgtech.com)